

TECHNISCHE INFORMATIONEN

Fenster- und Fassadenmarkisen

TYP ZIP 95 S

- schienengeführt

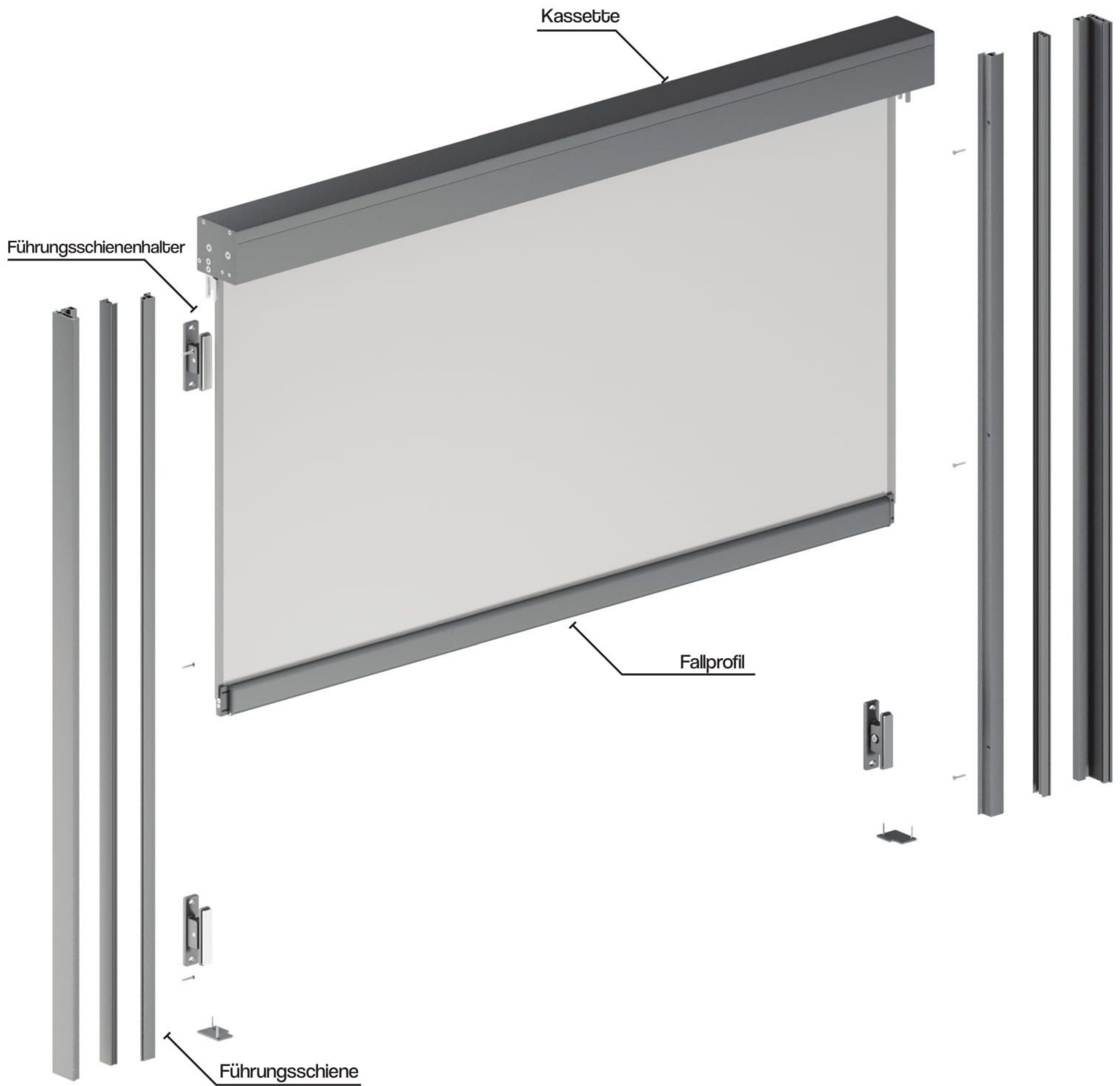

Farben	RAL
Elektroantrieb	ja
Manueller Antrieb	nein
Maximale Breite	3.0 m
Maximale Höhe	3.0 m
Außenverwendung	ja
Innenverwendung	nein

ABMESSUNGEN

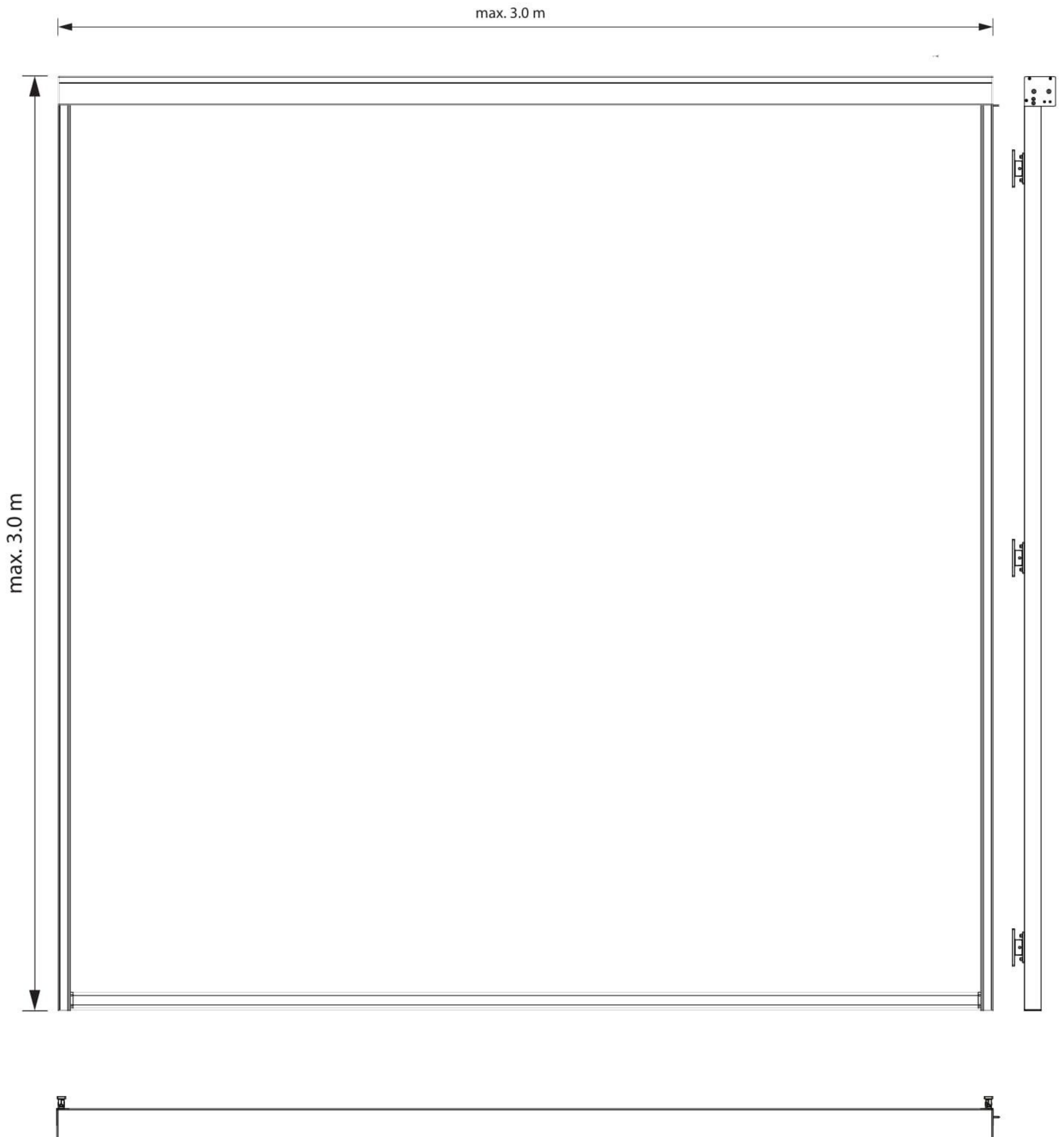

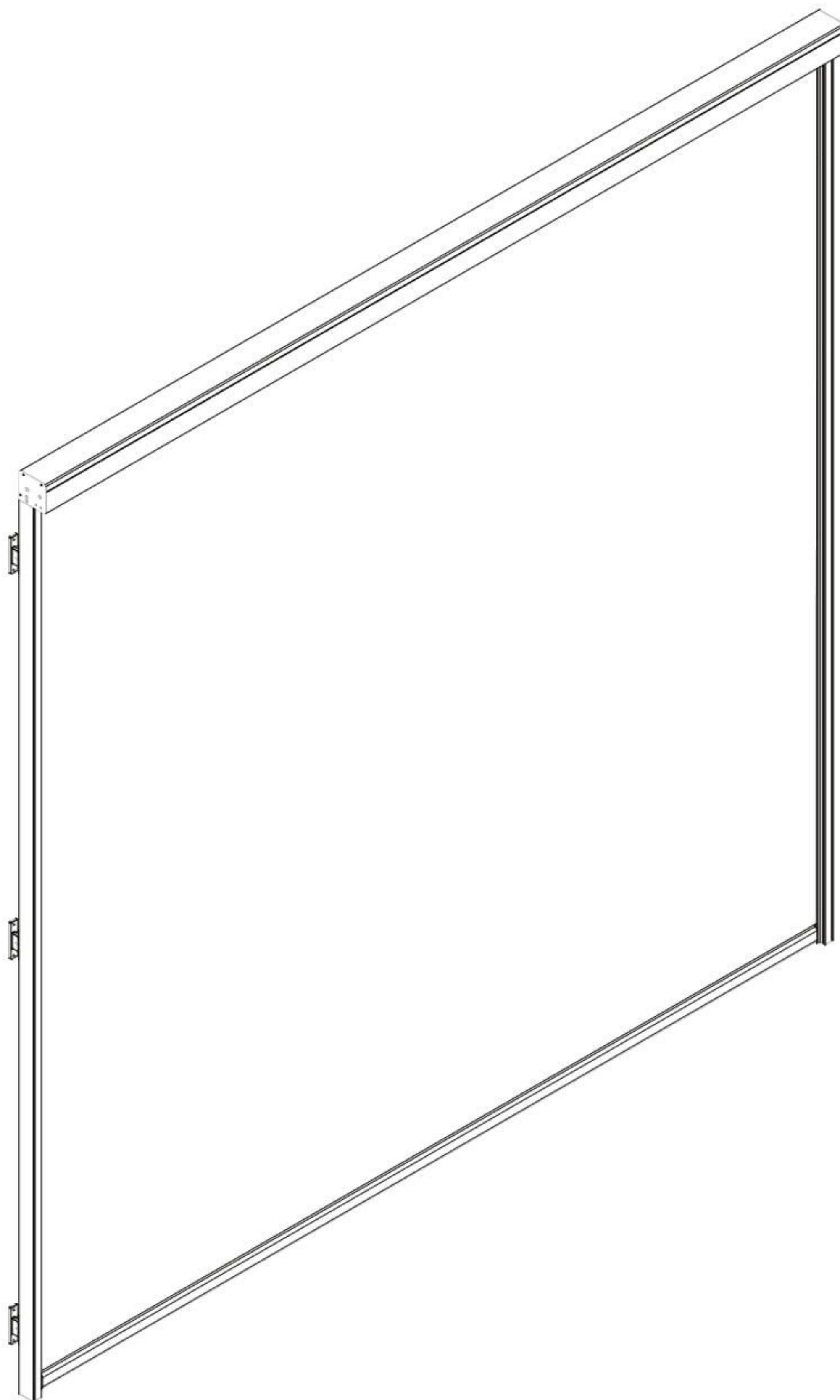

-  FG42 Seilführung Ø2.5
-  FG42R ● Seilführung Ø10
-  FP33  G31
-  R85  G80
-  Wind-schutzprofil PPW  GC30
-  Ø35  GC30F
-  Ø42  GC30FD
-  FG120  GC30R
-  FG51  G58
-  FD40  G40Z
-  **G40Z-02**

Führungsschienen

	Seil Ø 2.5 mm	Seil Ø 10mm	G31	G80	GC30	GC30F	GC30FD	GC30R	G58	G40Z	G40Z-02	ohne	
Fallprofil	FG42												
	FG42R												
	FP33												
	R85												
	Ø35												
	Ø42												
	FG120												
	FG51												
	Zusätzliche Profile	PPW											
		FD40											

Profil der Führungsschiene ZiP 95 Hauptabmessungen

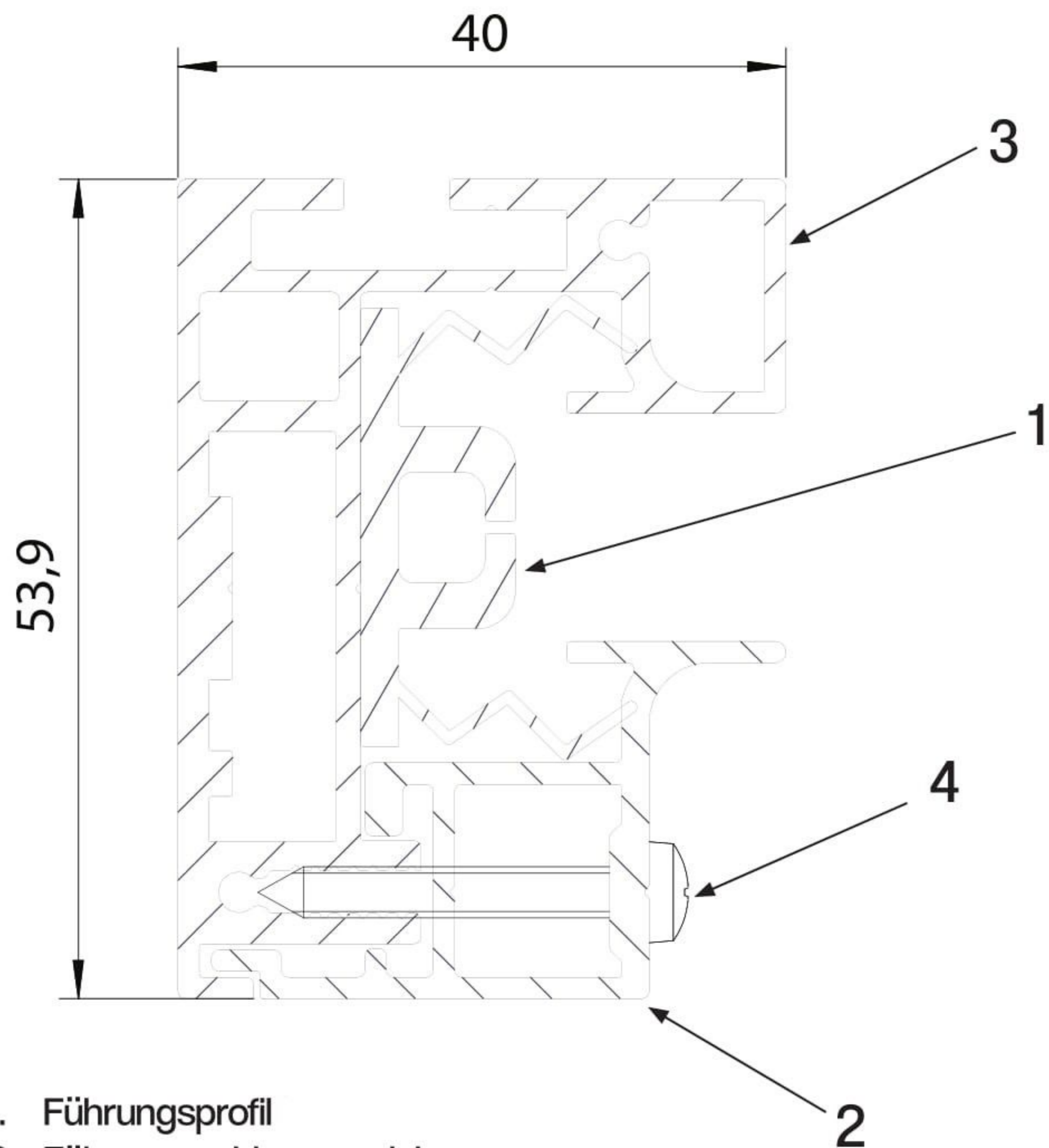

1. Führungsprofil
2. Führungsschienenrevision
3. Führungsschiene (fester Teil)
4. Befestigungsschraube

Fallprofil FG51

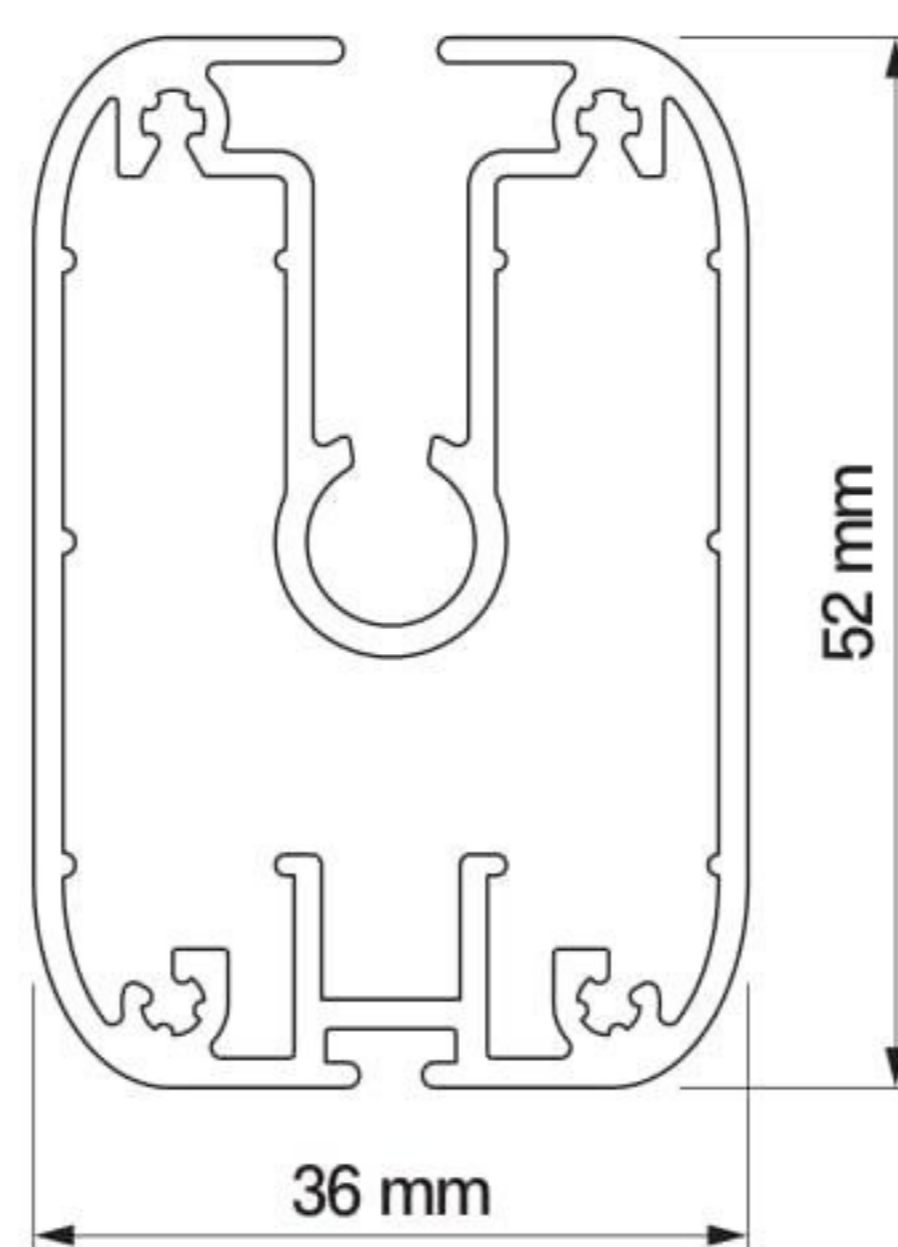

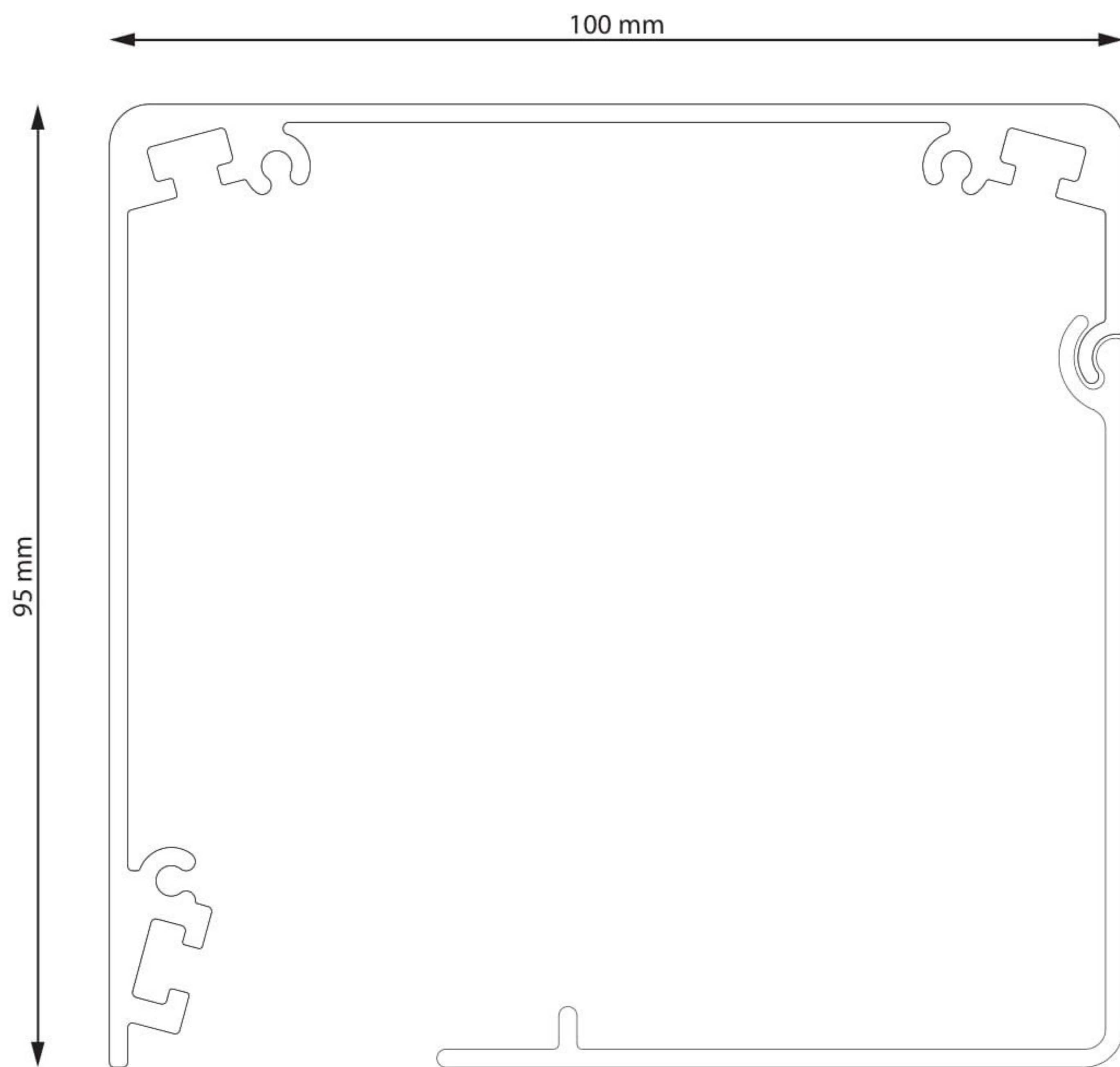
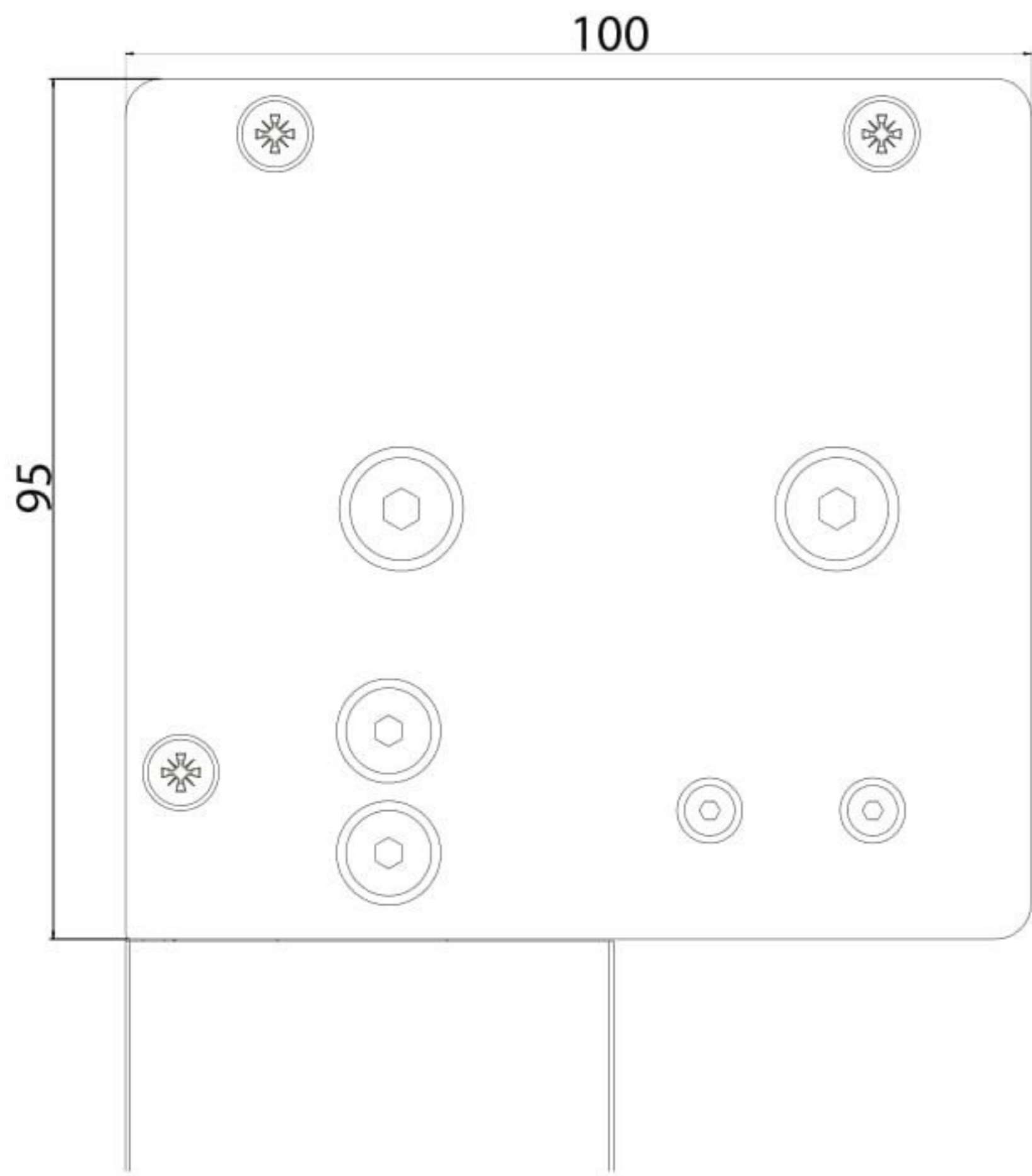

ZiiiP 95 Querschnitt der Kassette

Behang ZiP95. Freitragende Version auf regulierbaren Haltern.
Längsschnitt

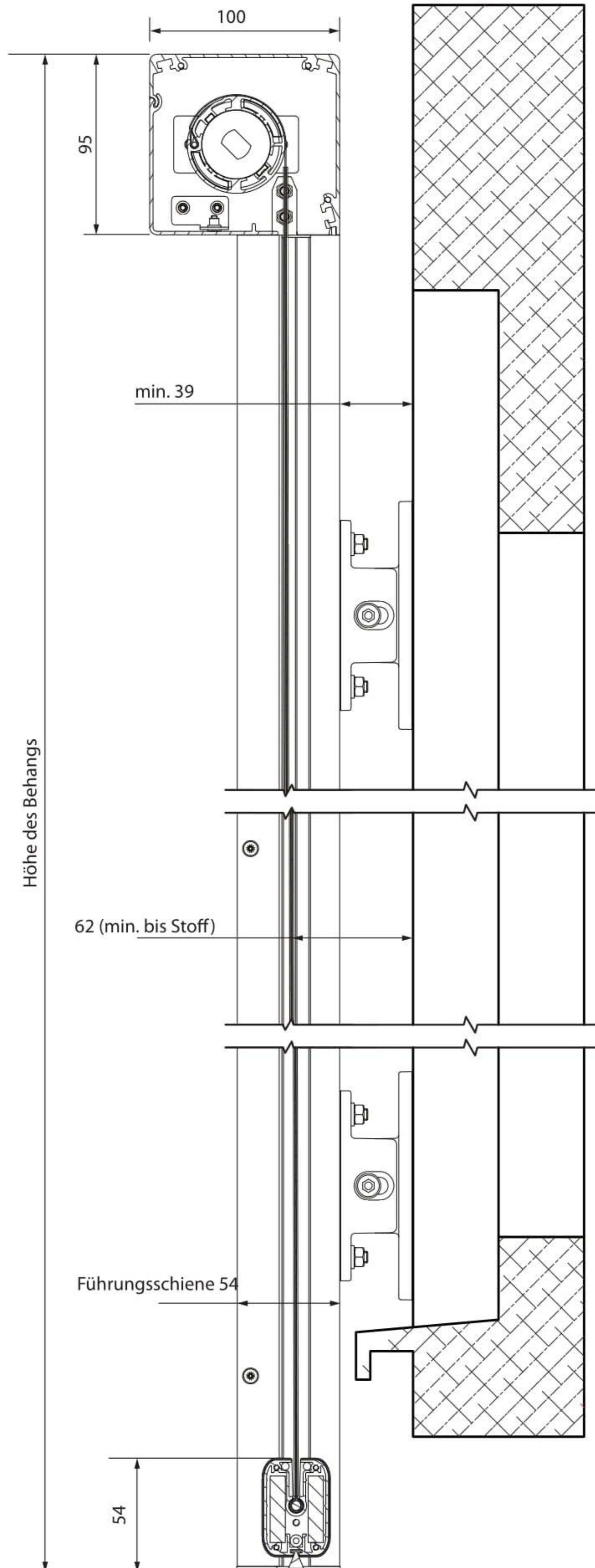

Behang ZiP95. Direkte Wandbefestigung, Frontal.
Längsschnitt

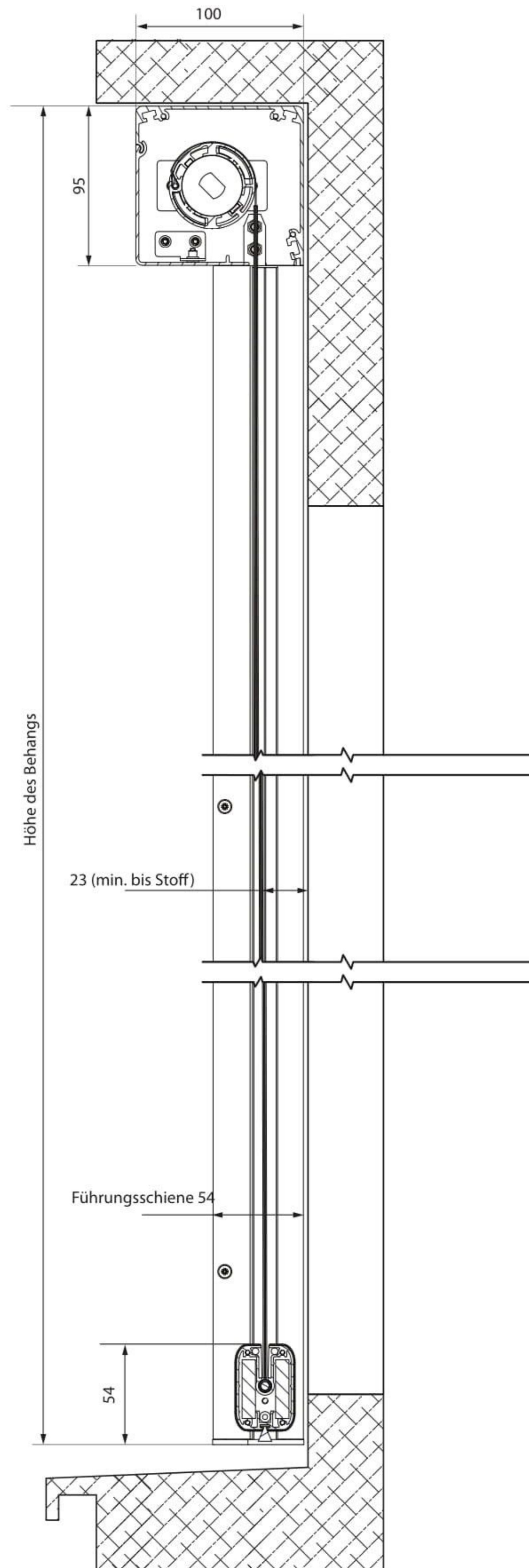

Behang ZIP95. Freitragende Version auf regulierbaren Haltern.
 Querschnitt der Kasette.

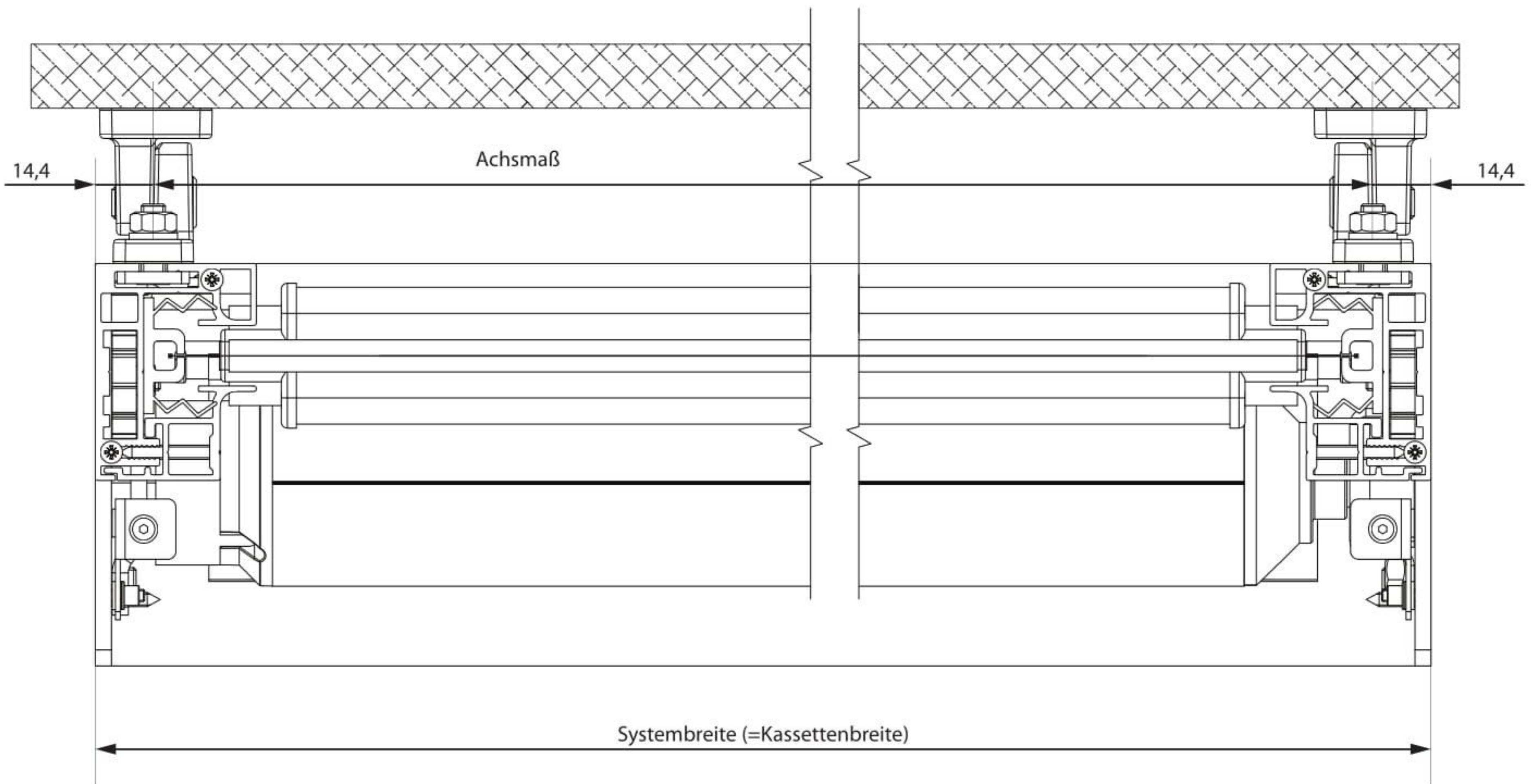

Behang ZIP95. Freitragende Version auf regulierbaren Haltern.
 Querschnitt des Fallprofils.

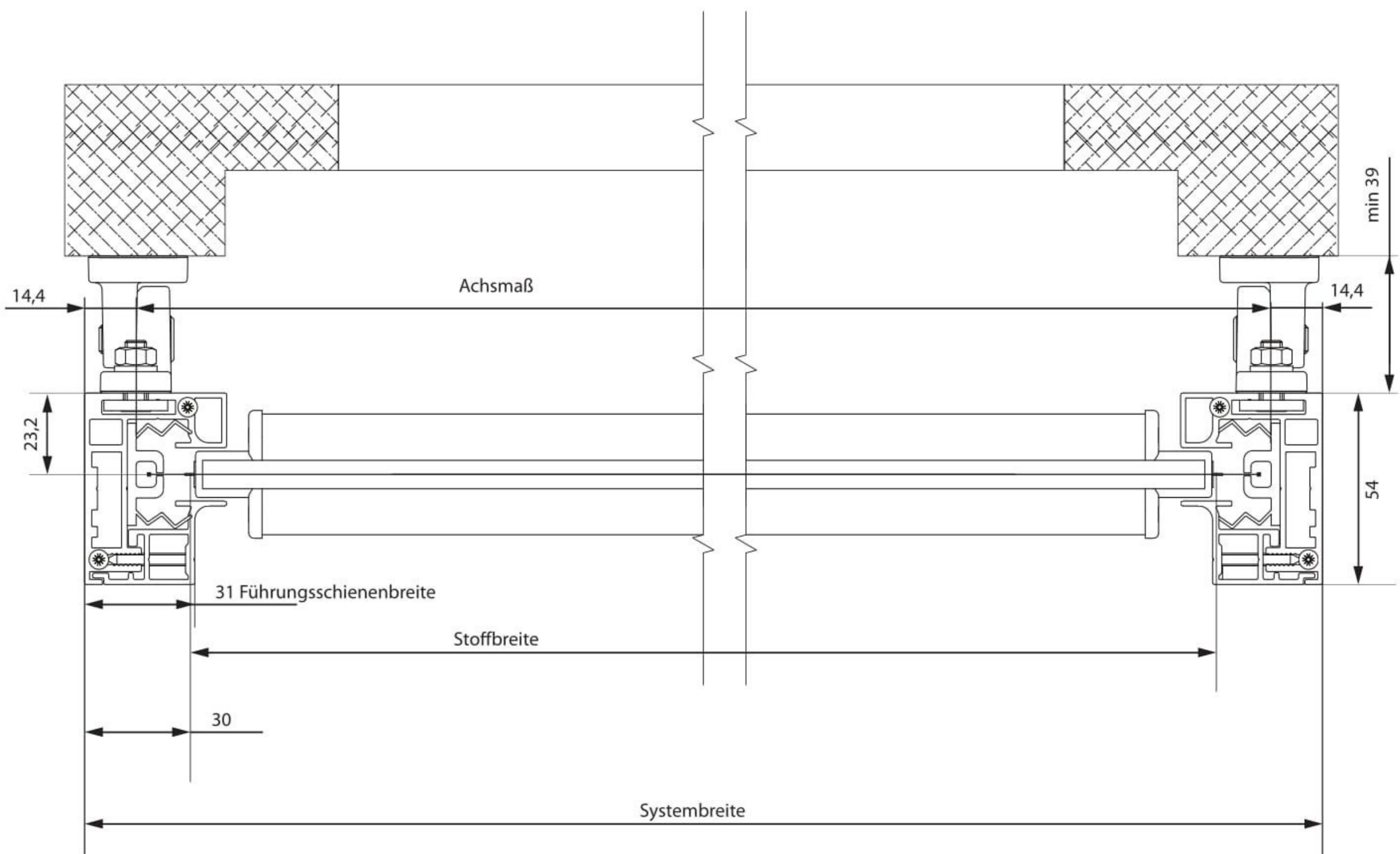

Behang ZIP95. Direkte Wandbefestigung, Frontal.
 Querschnitt der Kasette.

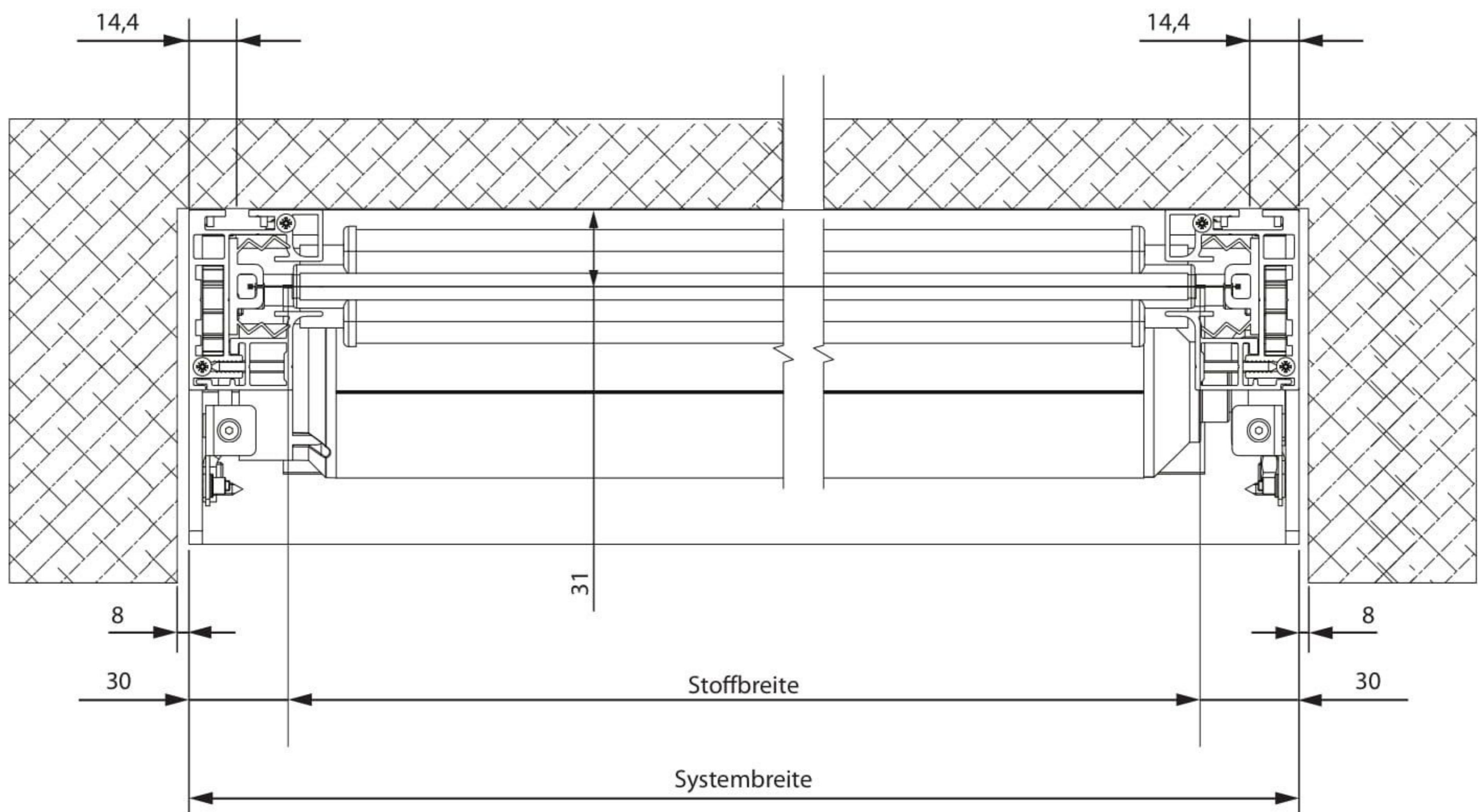

Behang ZIP95. Direkte Wandbefestigung, Frontal.
 Querschnitt des Fallprofils.

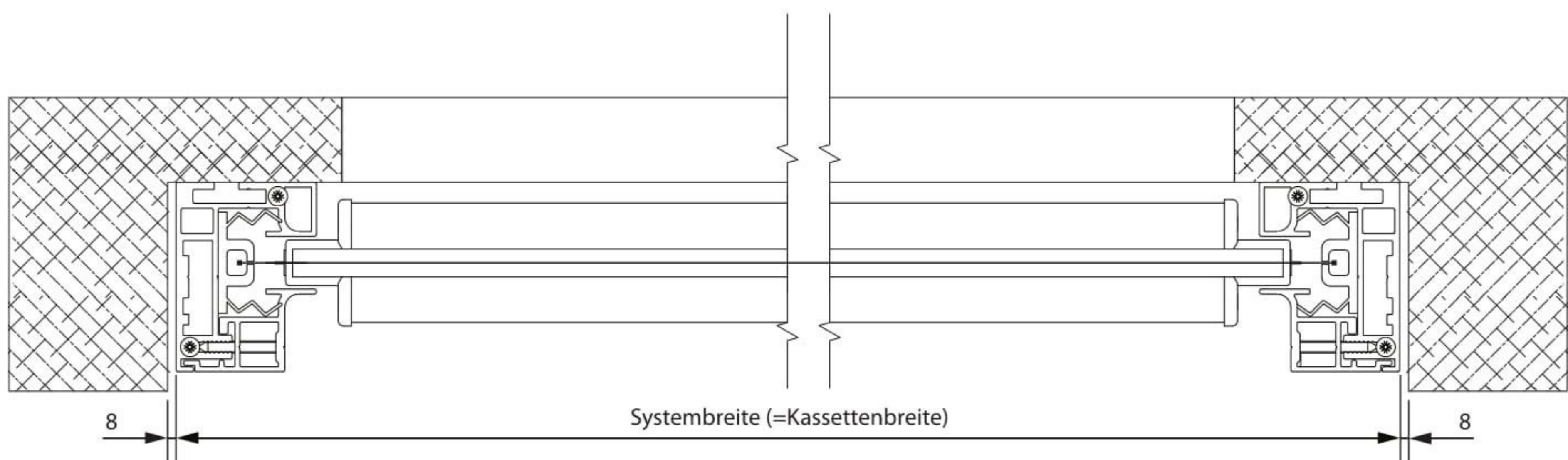

Freitragender Halter Typ A

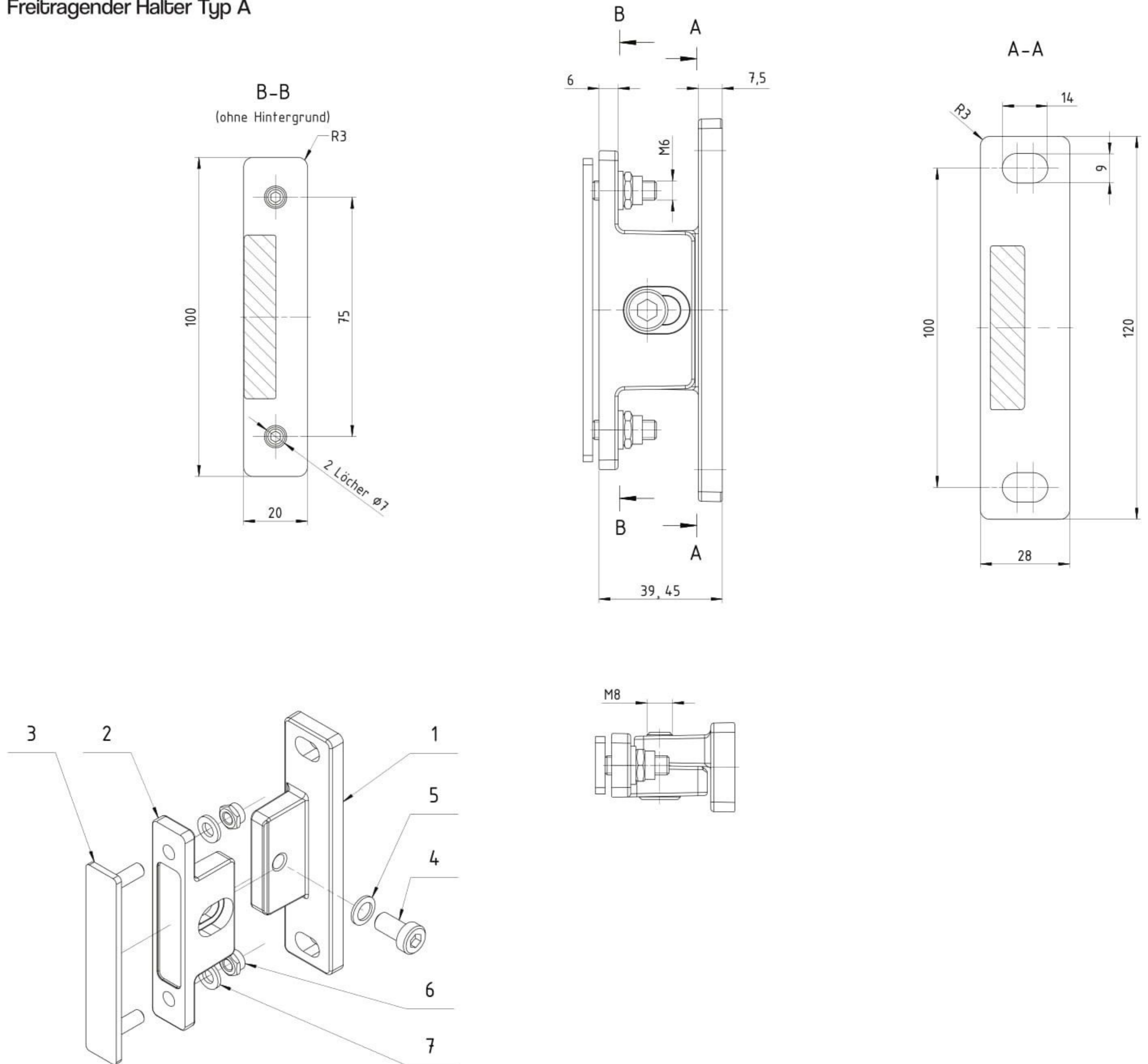

7	2	Unterlegscheibe 6,4	PN EN ISO 7090	A2	0,001 kg		
6	2	Selbstsichernde Mutter M6-A2	PN EN ISO 10511	A2	0,002 kg		
5	1	Sicherungsscheibe Ø 8 mm	ART_NR_420500__ HX_0__	Verzinkt	0,000 kg		Metrisch
4	1	Zylinderschraube 6-Kant M8X16-A2-70	DIN 7984	A2-70	0,010 kg		
3	1	Befestigung des freitragenden Halters	123.011.000		0,049 kg		
2	1	Regulierbarer Teil des freitragenden Halters	123.005.002	EN AC 44300	0,053 kg		
1	1	Wandteil (für Reflektol)	123.005.001	EN AC 44300	0,088 kg		
Lp.	Menge	Bezeichnung	Zeichnungsnr. oder Norm	Material	Gewicht	Beschichtete Oberfläche	Bemerkungen
Teileliste							

Freitragender Halter Typ B

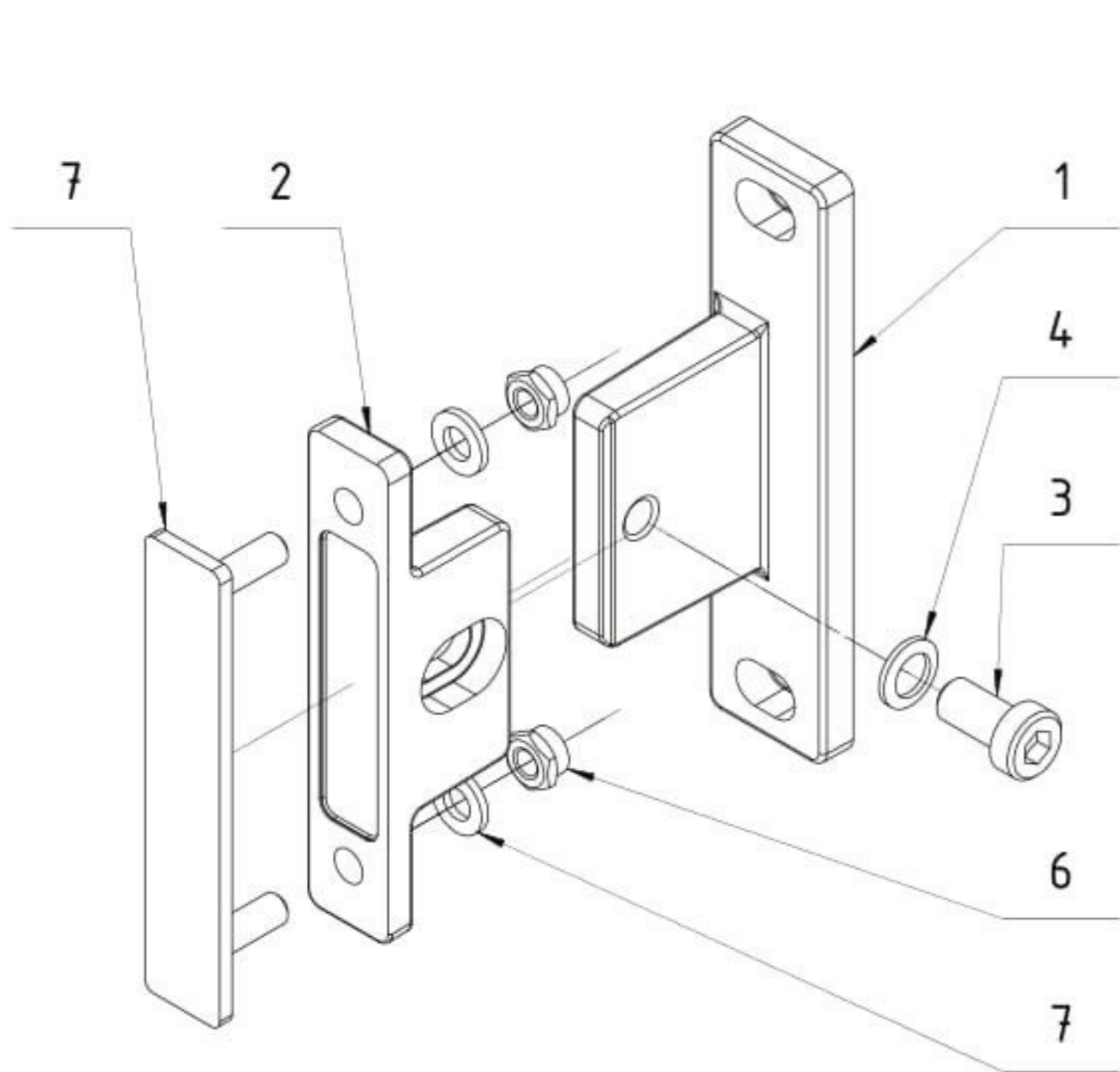
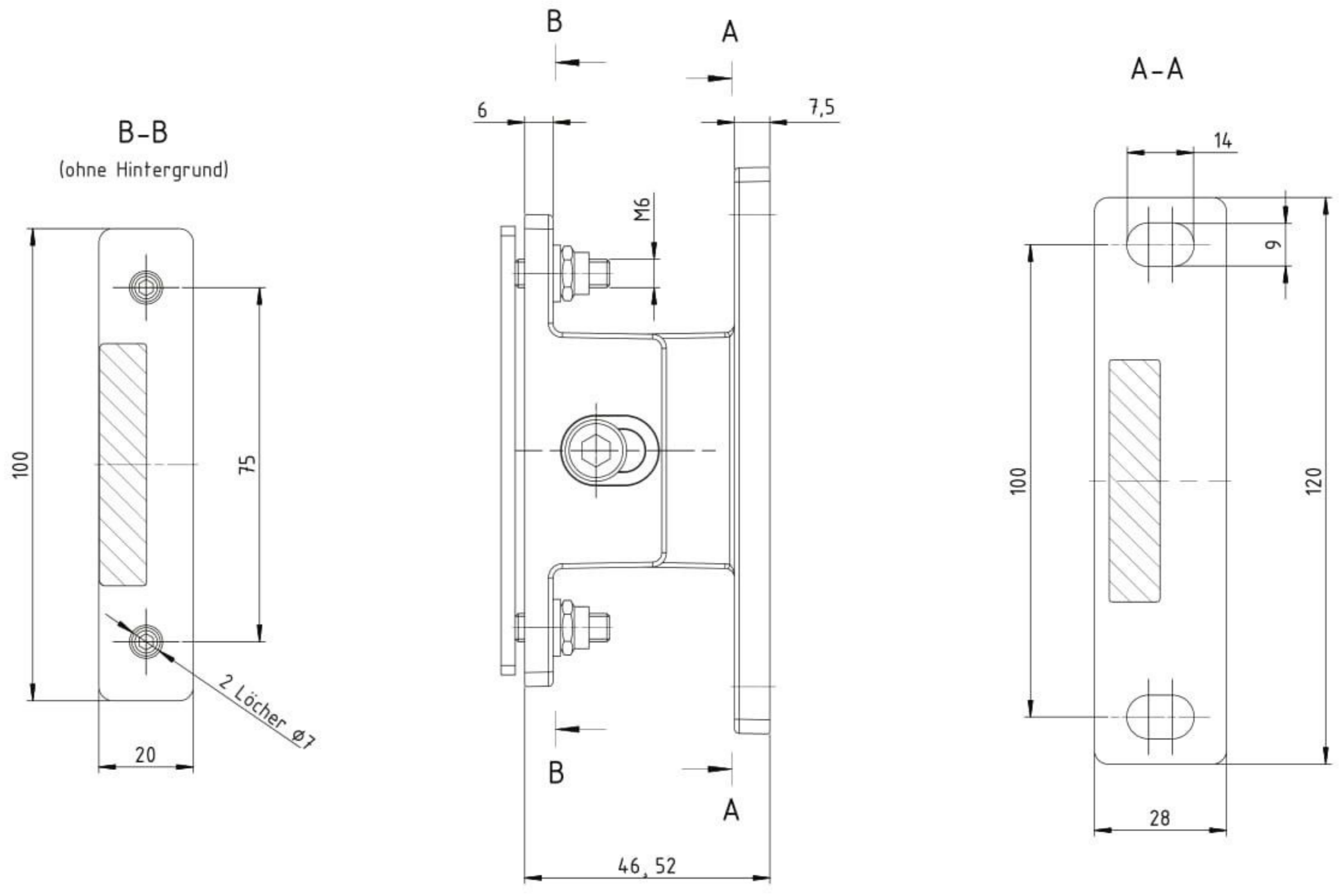

7	2	Unterlegscheibe DIN 125 6.4	PN EN ISO 7090	A2	0,001 kg		
6	2	Selbstsichernde Mutter M6-A2	PN EN ISO 10511	A2	0,002 kg		
5	1	Sicherungsscheibe Ø 8 mm	ART_NR_420500__ HX_0__	Verzinkt	0,000 kg		Metrisch
4	1	Zylinderschraube 6-Kant M8X16-A2-70	DIN 6912	A2-70	0,010 kg		
3	1	Befestigung des freitragenden Halters	123.011.000		0,049 kg		
2	1	Regulierbarer Teil des freitragenden Halters	123.005.002	EN AC 44300	0,053 kg		
1	1	Wandteil (für Raffstoren)	123.006.001	EN AC 44300	0,088 kg		
Lp.	Menge	Bezeichnung	Zeichnungsnr. oder Norm	Material	Gewicht	Beschichtete Oberfläche	Bemerkungen
Teilleiste							

Befestigung des Führungsschienenhalters an der Führungsschiene

Halter A

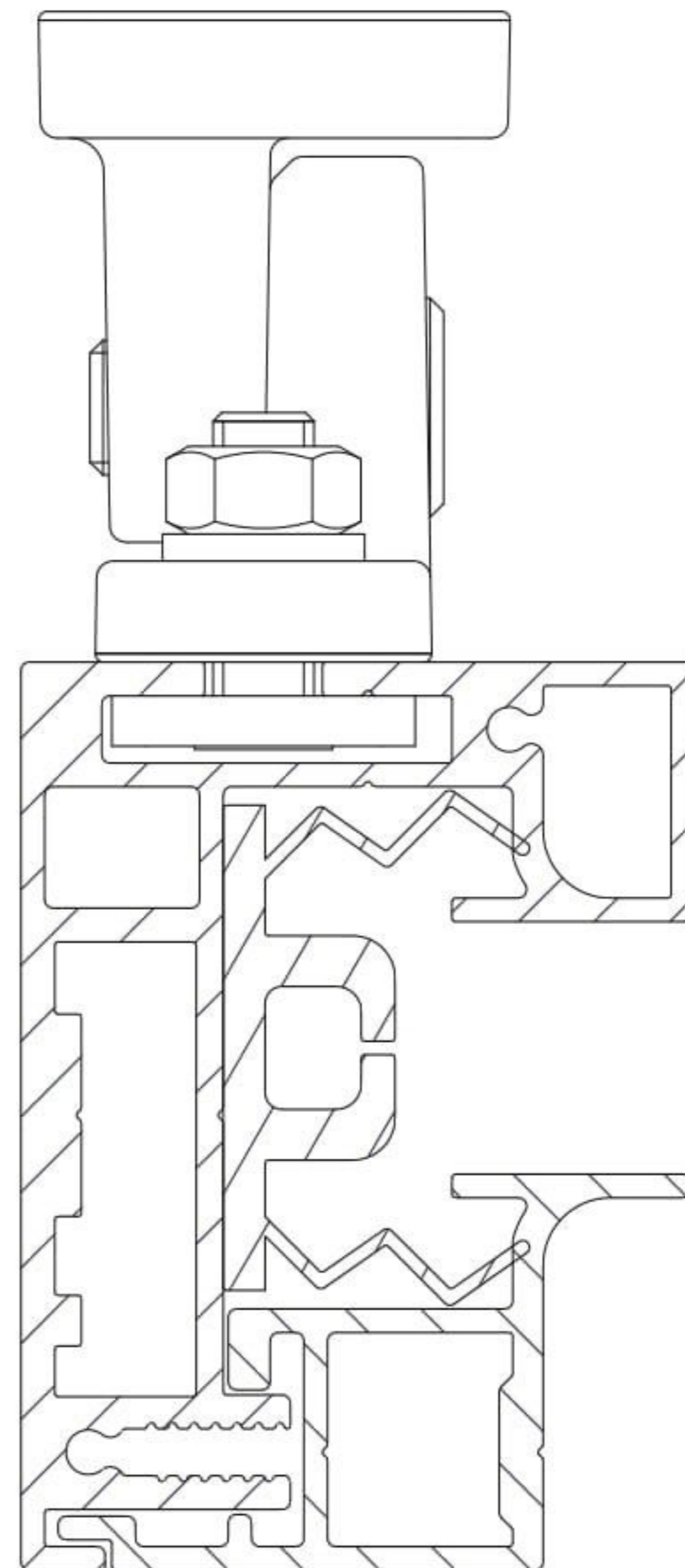

Halter B

