

TECHNISCHE ERGÄNZUNG SHUTTERS

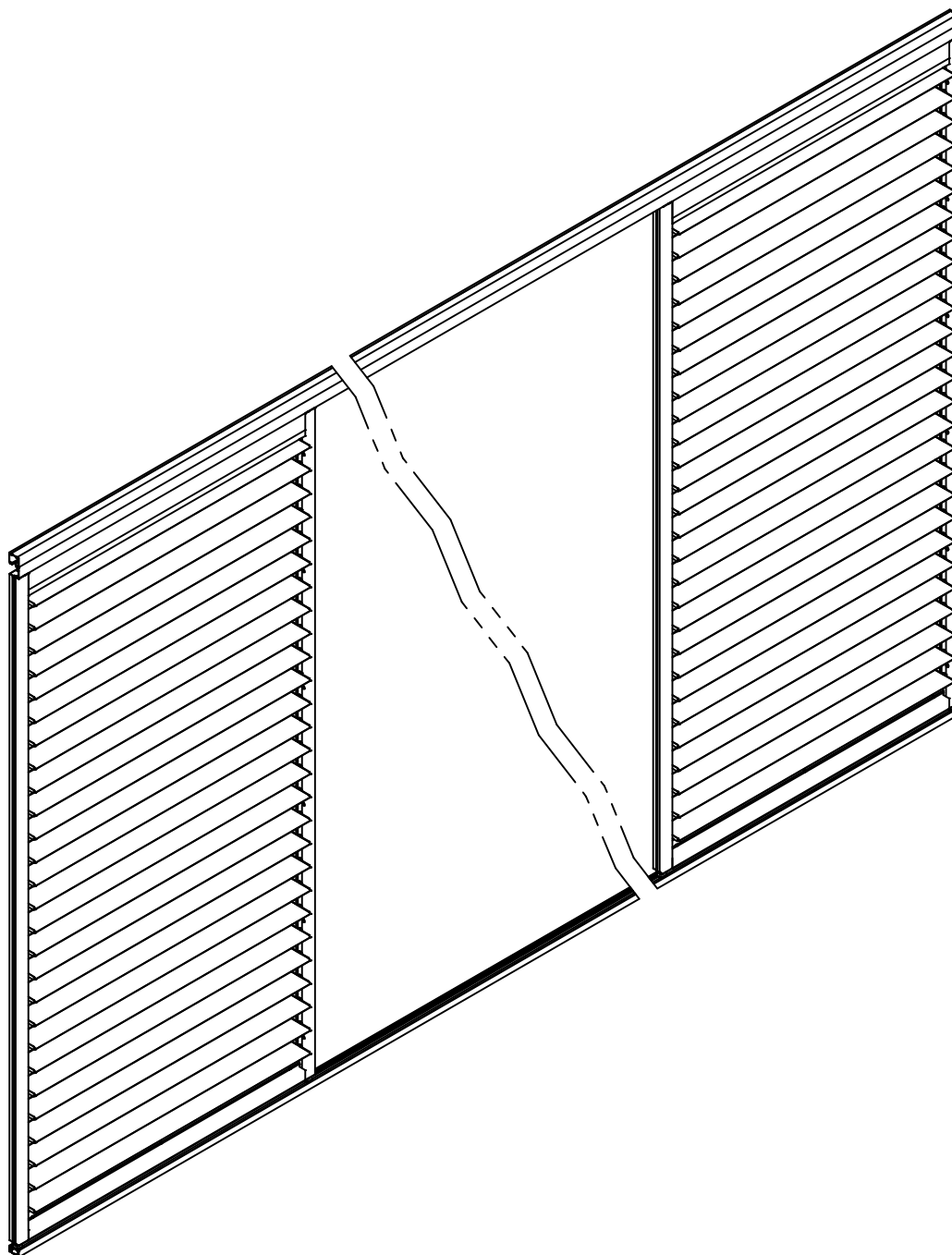

OBERE SCHIENE

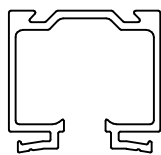

WINKEL

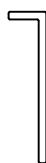

UNTERE SCHIENE



PANEEL

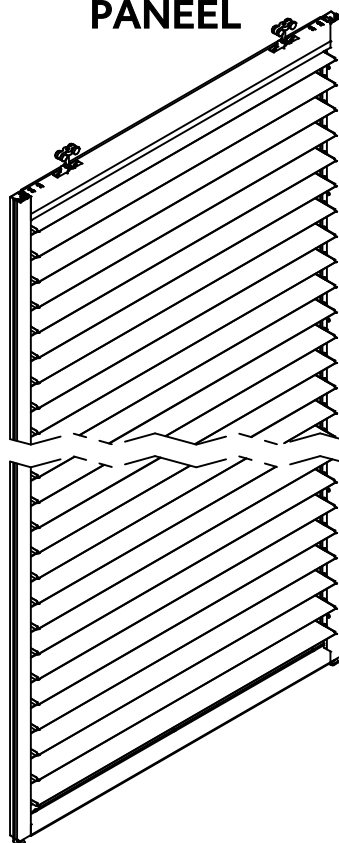

Vertikaldurchschnitt des Shutter systems

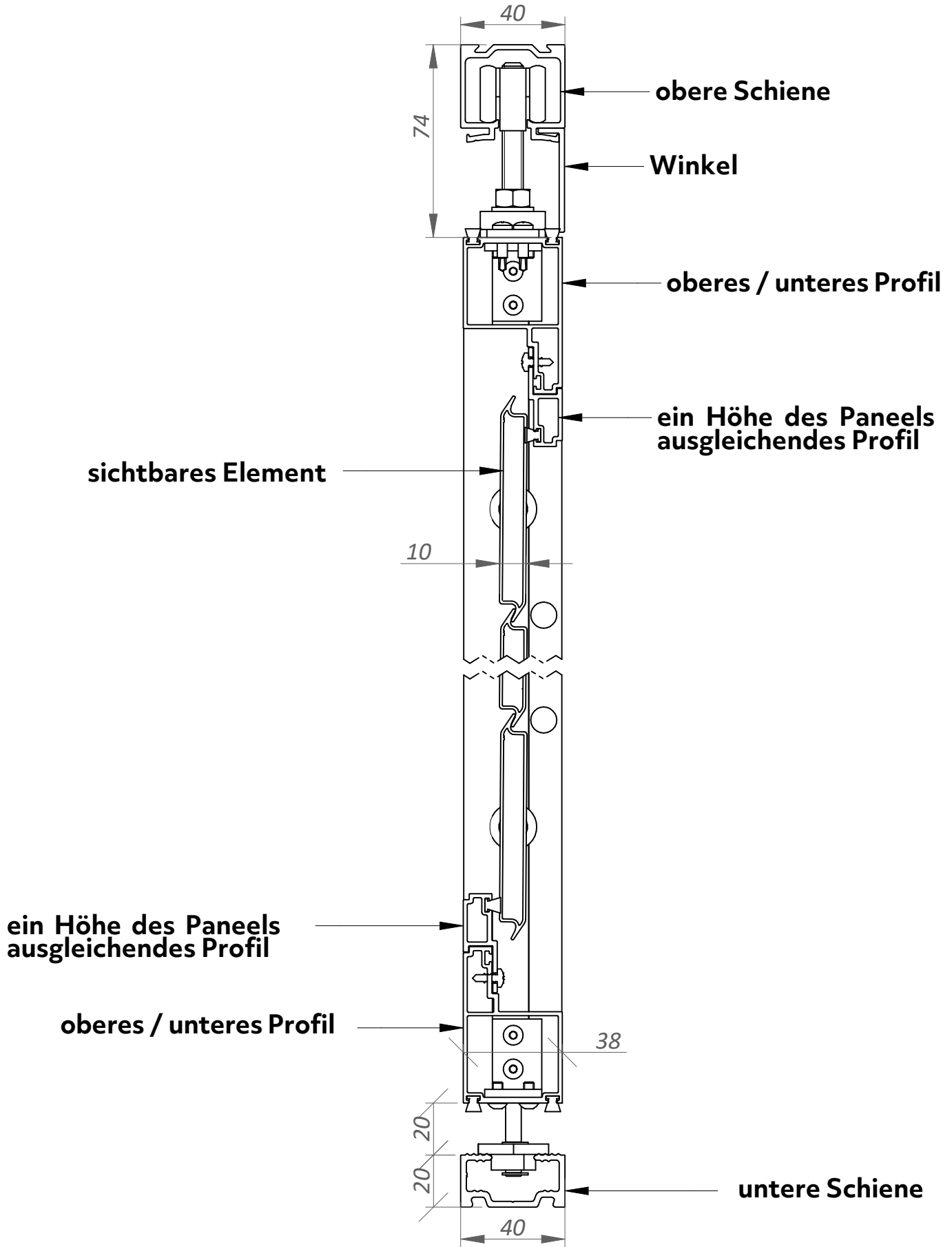

Horizontalschnitt des Panels

Zahnriemen

Zahnrad

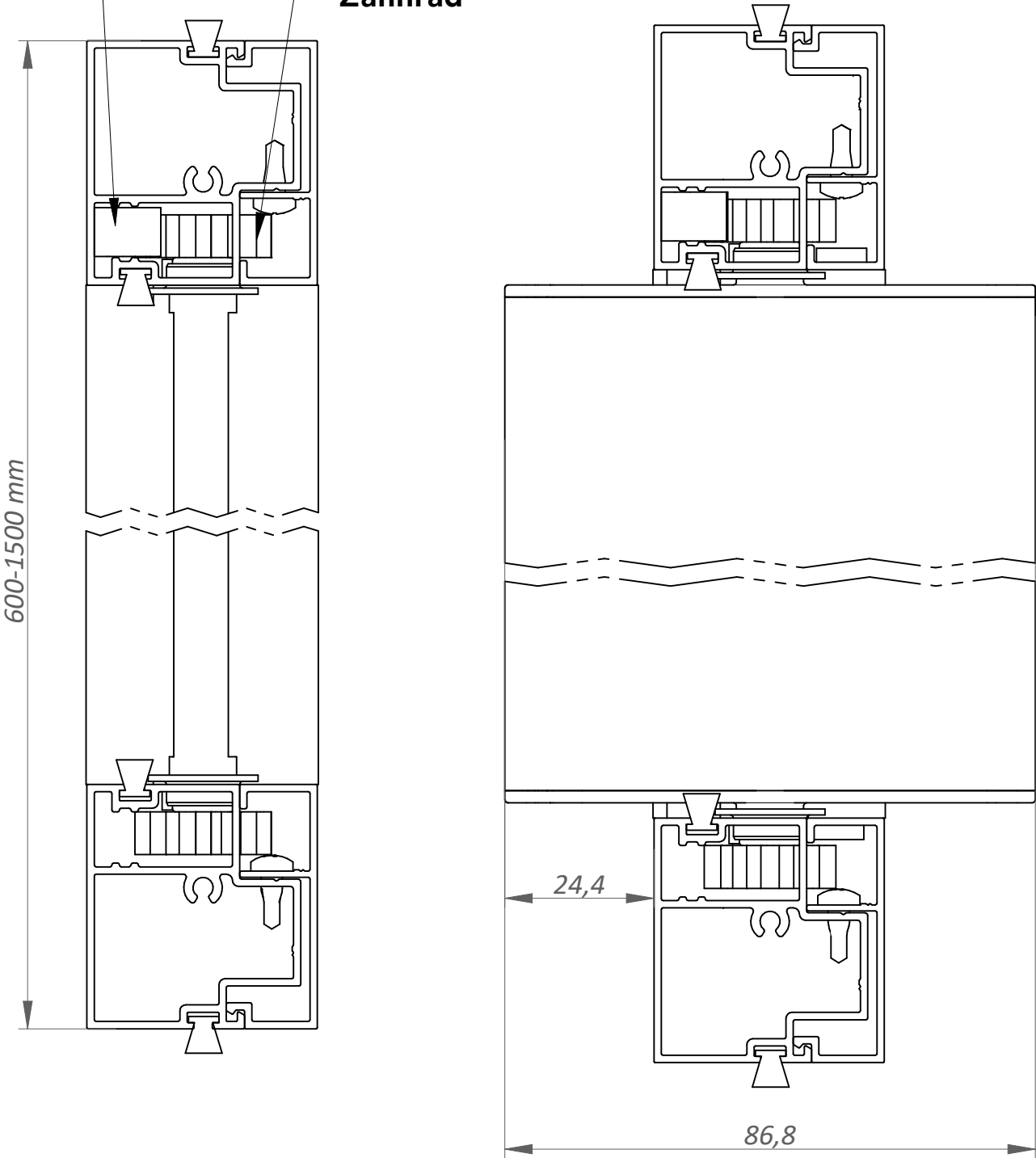

KASKADERSCHNITT

AUFRISS

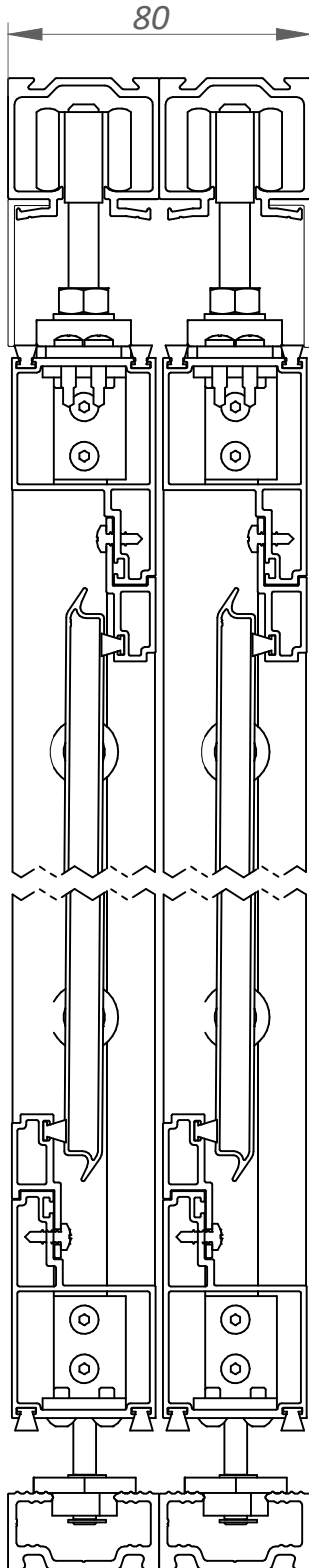

GRUNDRISS

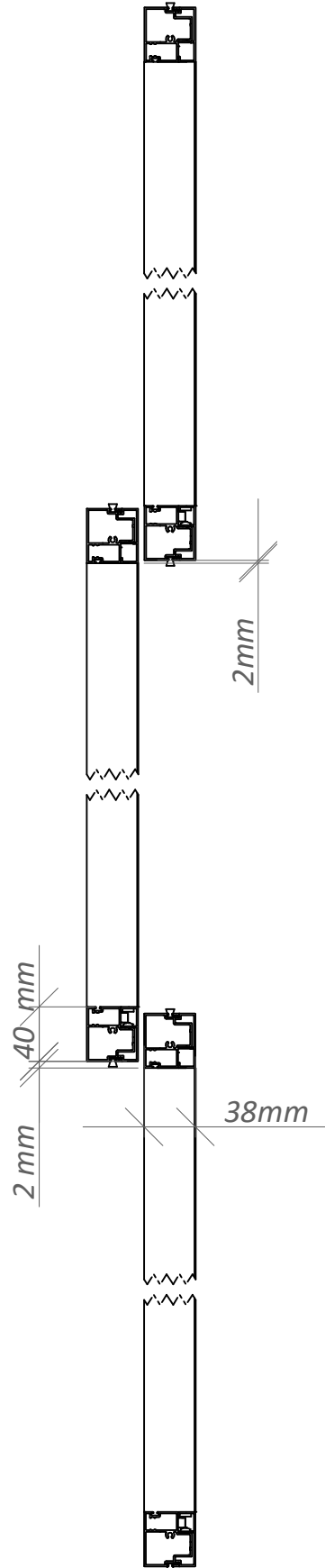

MÖGLICHE KONFIGURATIONEN



SEITENRISS DES PANEELS

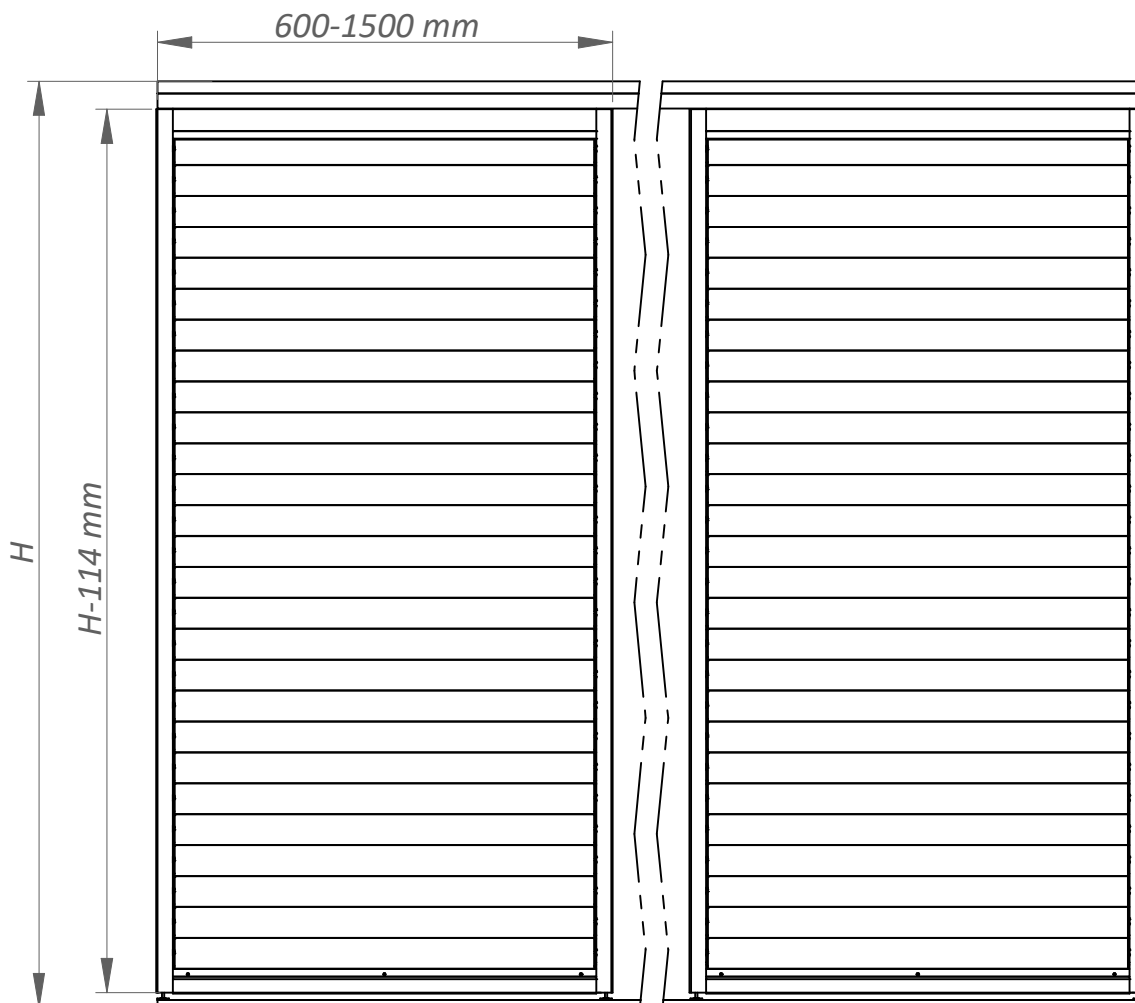

ELEMENTE DER LAMELLEN

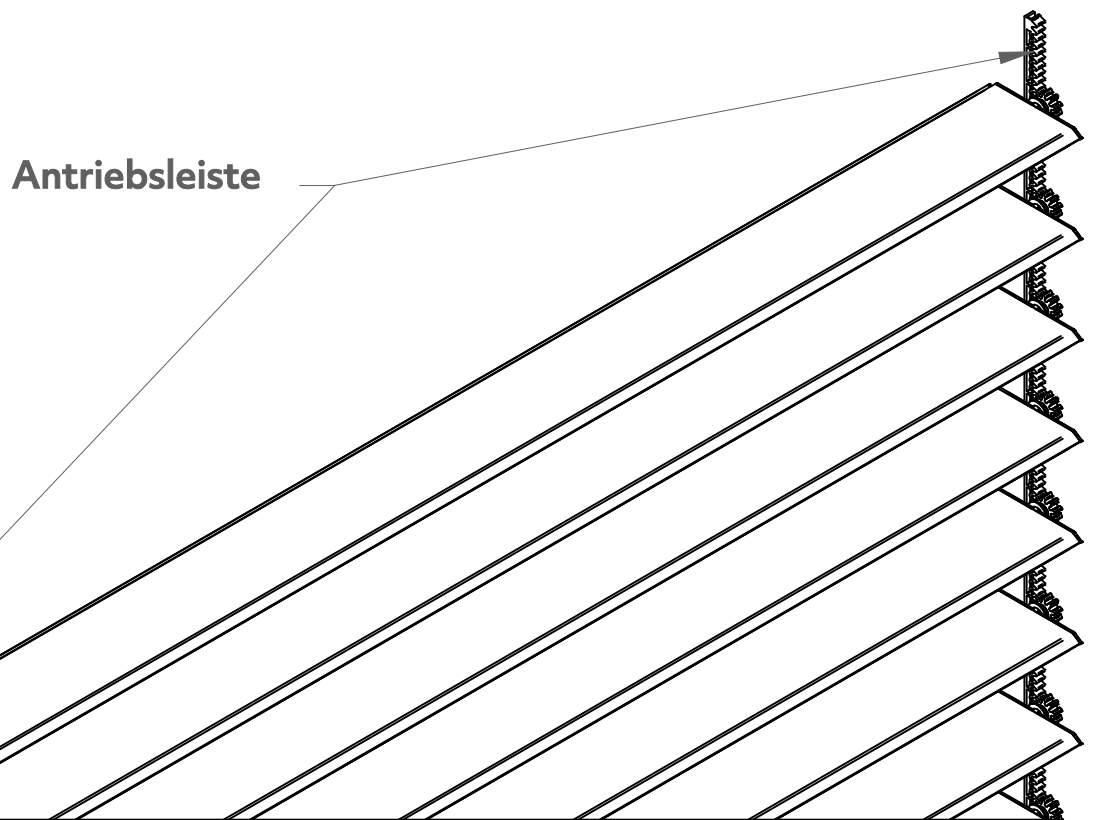
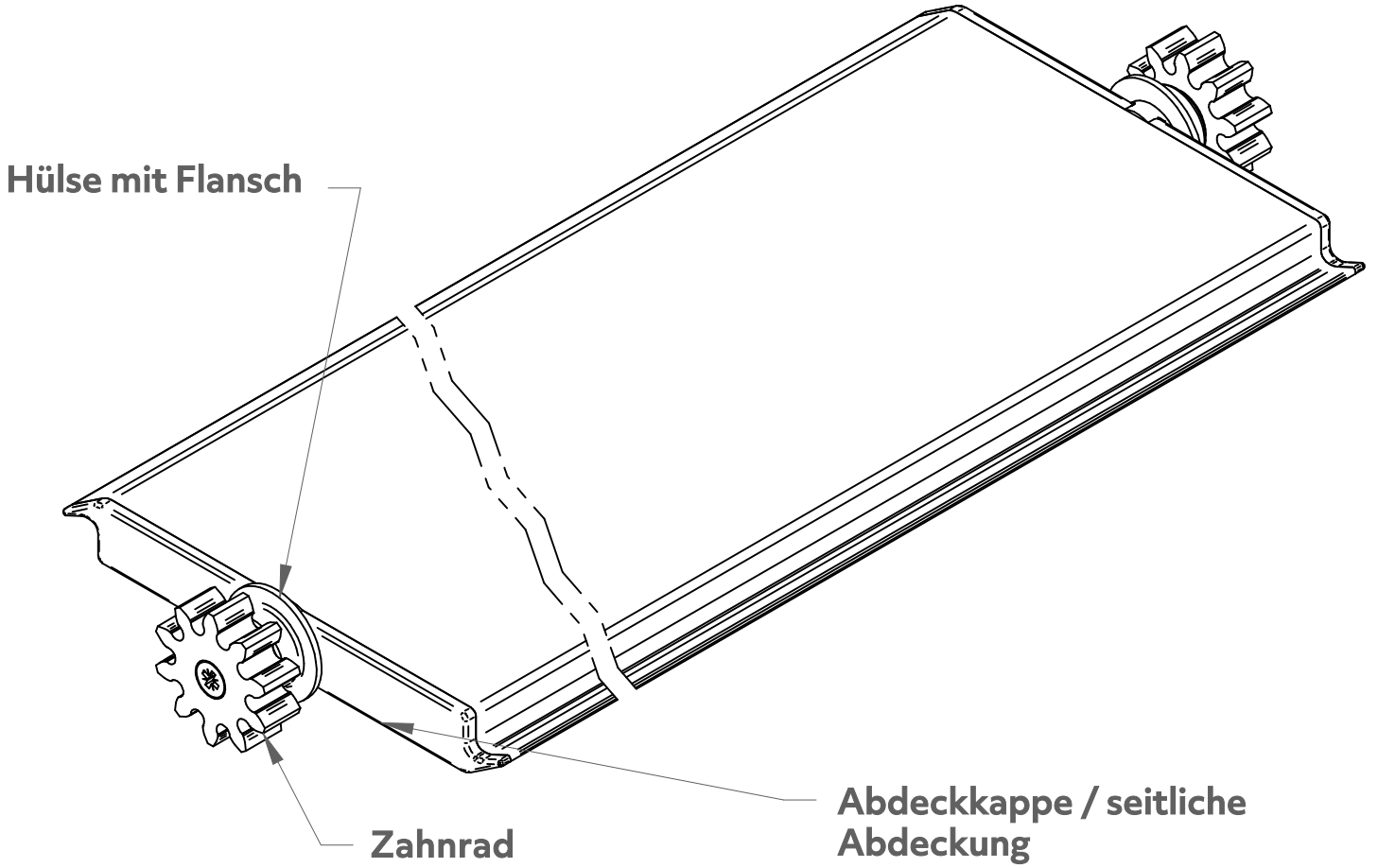

MÖGLICHKEIT DER MONTAGE DES PANEELS ALS FIX

